

ACAST Series 2/2 Normally Closed

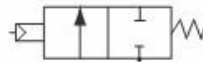

Features & Benefits

- Angled body provides higher flow rates
- Anti-water hammer design (flow under seat)
- Operator rotatable through 360°
- Optical position indicator
- Compact valve body design
- 1/2" to 2" sizes available, NPT, BSP, Butt or Socket Weld
- High life expectancy
- Maintenance free gland
- 31 series acts as the pilot valve
- Double acting option



Single Acting

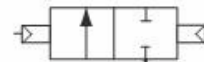

Double Acting
(Option)

Specifications

Function (Single Acting):	Normally Closed, air to open, spring to close
Function (Double Acting):	Normally Closed, air to open, air to close
Ambient Temperature:	-10°C to +50°C
Maximum Viscosity:	600cST
Body Material (Std):	Stainless Steel 316
Springs:	Stainless Steel 302
Seal Material (Std):	PTFE
Pilot Connection:	1/8" NPT
Min Pilot Pressure:	3 Bar
Max Pilot Pressure:	8 Bar
Pilot Temp Range:	-10°C to +60°C
Connection Type (Std):	BSP

Features

Single Acting

Pipe Size	Kv	OPD (Bar)	Weight (Kg)	P.Max Bar	Orifice mm	Cat No.
3/8"	4	16	0.8	20	13	ACAST3
1/2"	4	16	0.8	20	13	ACAST4
3/4"	9	16	1.5	20	20	ACAST6
1"	18	16	2.0	20	25	ACAST7
1 1/4"	25	16	3.0	20	32	ACAST8
1 1/2"	38	16	4.0	20	40	ACAST9
2"	52	16	4.7	20	50	ACAST10

ACAST Series Pressure Chart
(flow below seat)

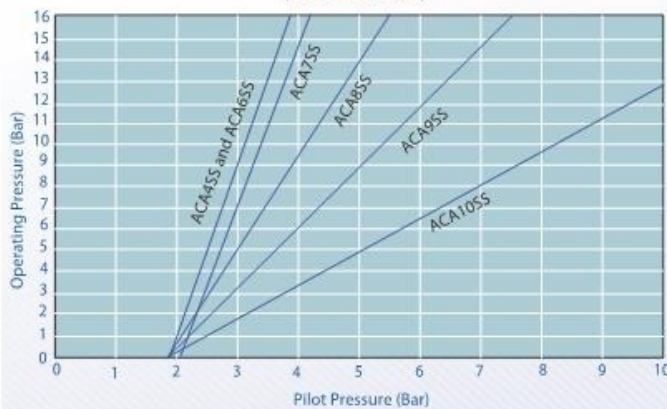

ACAST Series Pressure Chart
(flow above seat)

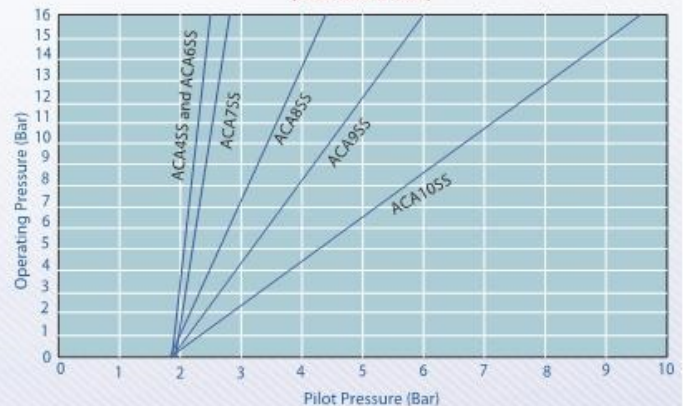

Morrel International S.r.l.

Tel. +39 023560433

Tel. +39 023560452

Fax +39 023562627

E-mail: morrel_int_srl@yahoo.it

ACAST Series 2/2 Normally Closed

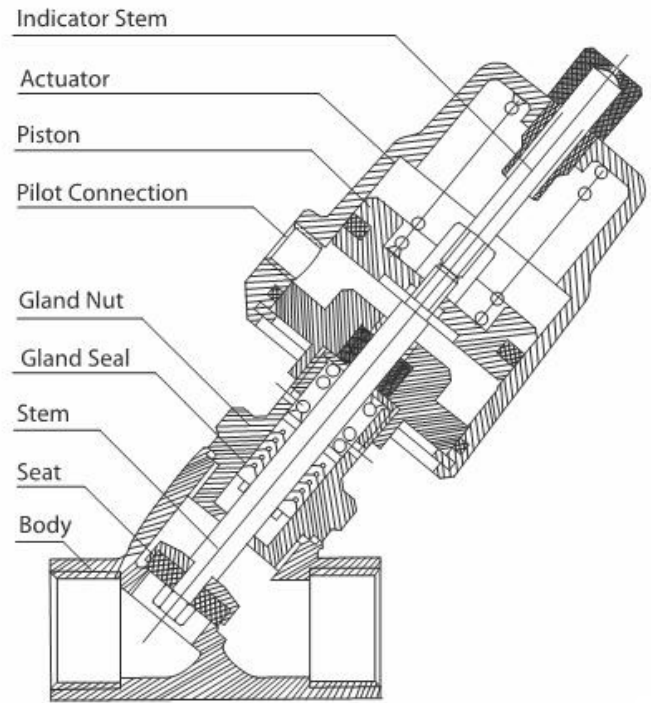
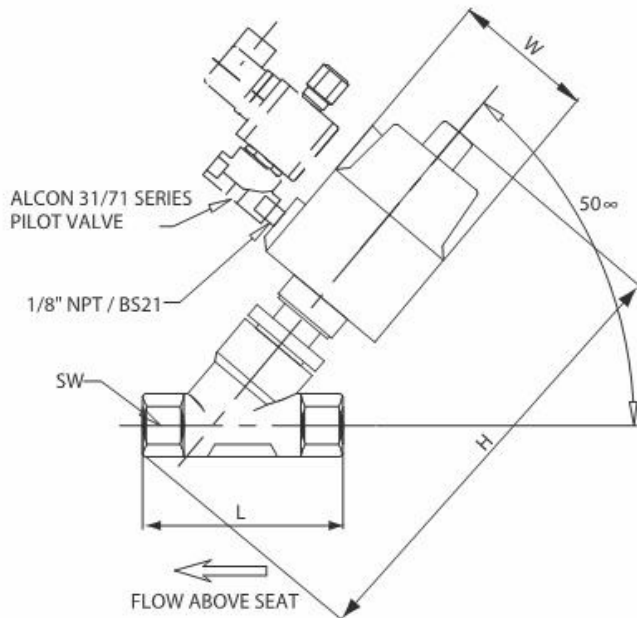

Dimensions

Size	L	H	W
1/2"	90	215	64
3/4"	90	225	64
1"	105	235	64
1 1/4"	120	235	64
1 1/2"	140	265	100
2"	150	275	100

Dimensions given in mm

Mounting bracket option available

Namur mounting plate option

Socket weld option

ANSI and PN flange options

Mounting

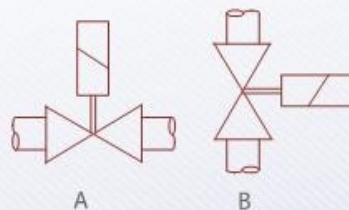

ACAST with optional
positional indicator
(open & closed) EExia

Morrel International S.r.l.

Tel. +39 023560433

Tel. +39 023560452

Fax +39 023562627

E-mail: morrel_int_srl@yahoo.it