

**ELETTOVALVOLA A 5 VIE
 A RIARMO MANUALE**

EDR 455

Modello EDR 455

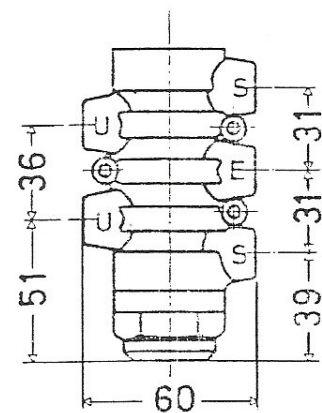
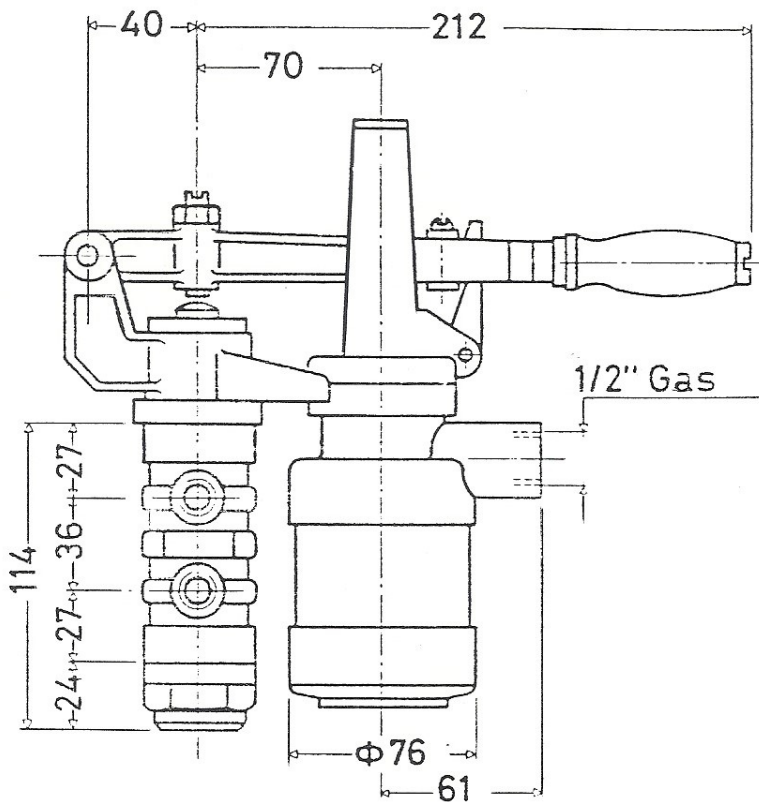
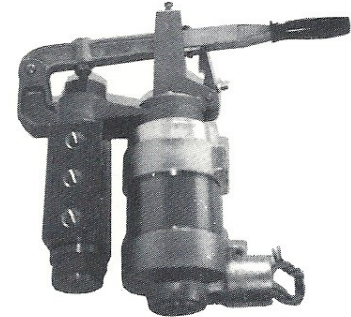

Pressione: 0 ÷ 10 Kg/cmq.

Coefficiente di portata: Kv = 16

Potenza assorbita: 28 W

Custodia bobina: STD, IP55 o EExd

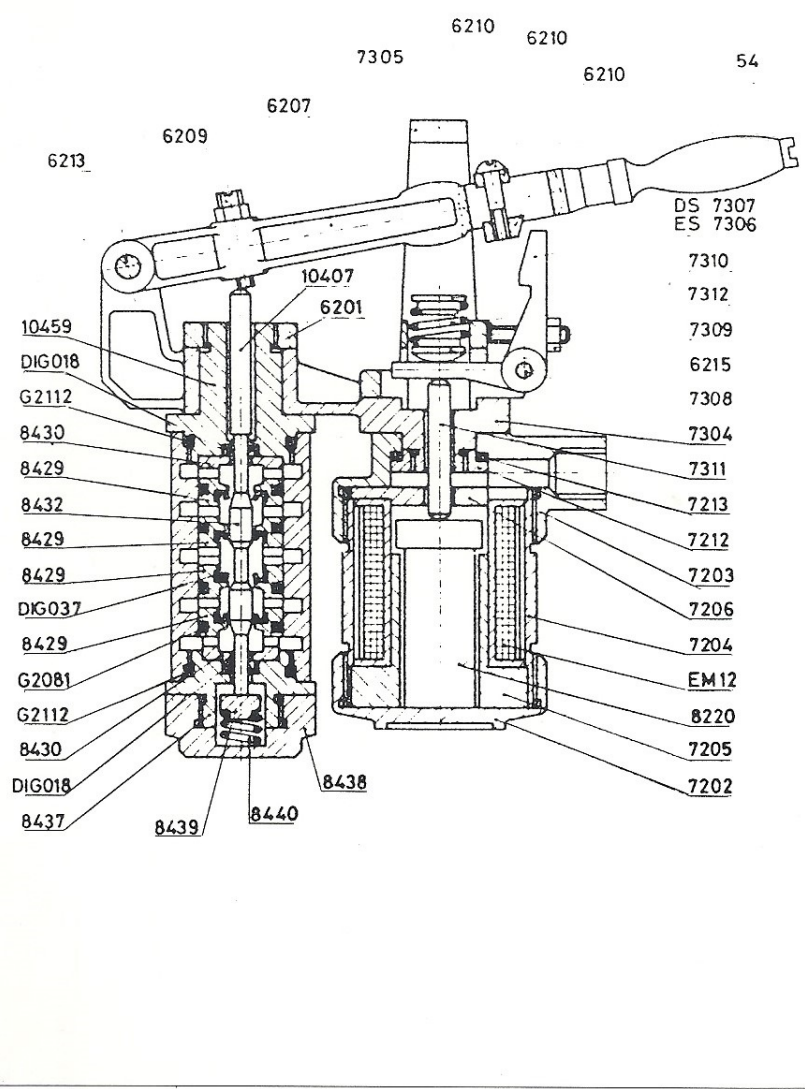

ATTENZIONE:

Richiedendo le parti di ricambio precisare

1° Il numero del peso desiderato

2° Il modello della valvola